

# Pressure Sensor

## Product Data Sheet

LOW  
INTERNAL  
VOLUME

FLUID  
ISOLATED  
SENSOR

FULLY SWEPT  
INLINE  
PATHWAY

### Precise, digital, inline pressure sensing for high performance fluidic systems

Our inline pressure sensor provides simplicity and convenience featuring extremely low internal volume and negligible pressure compliance. This component combines an entirely separated fluidic pathway, electronics, and I2C communication into a small package. Easily integrate our sensor into your system for precise pressure monitoring and fluid control.

#### How Inline Pressure Sensors Works

A fully isolated MEMS sensing element reacts instantly to physical pressure changes of the fluid transmitted through a gel-filled cavity. Signal conditioning, analog-to-digital conversion, and I2C are provided by the onboard electronics.

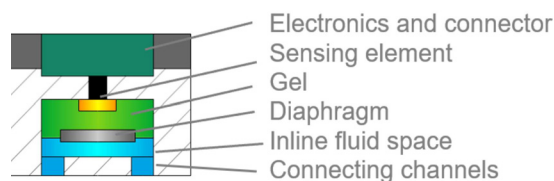

Internal anatomy of the manifold-mountable pressure sensor version; not to scale. Ports are located in the base element, which is not shown in the diagram.

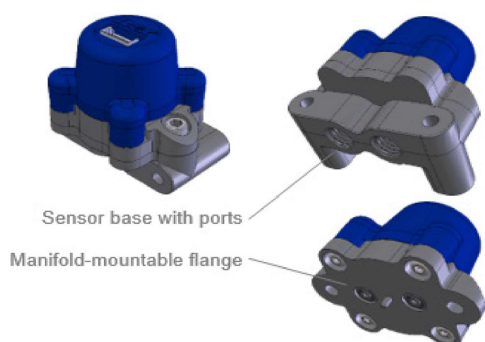

#### Features:

- › Fully swept inline pathway
- › Fluid-isolated sensor
- › Low internal volume
- › Manifold mountable or 1/4-28 UNF/M6 ports
- › Factory-calibrated
- › Fully I2C compliant device

#### Fluidic Applications:

- › Fluid actuation control
- › System diagnostics
- › Adaptive fluid control
- › Overpressure monitoring

#### System Applications:

- › Molecular platforms e.g. sequencing, protein detection and interaction, spatial biology
- › Flow cytometry
- › Vacuum-actuated systems

## General

Parameter	Value
Sensor series	Quickstart™
Sensor type	Capacitive MEMS sensing
Fluid interface	Inline fully-swept pathway
Fluid isolation	Diaphragm

## Maximum Ratings (Absolute)

Parameter	Value	Unit
Proof pressure	400	PSI
Burst pressure	800	PSI
Operating voltage	5.5	DC

## Fluidic

Parameter	Variant	Value	Unit
Media contact materials		Stainless steel 316L, FKM (Viton), PEEK	
Connection	Manifold	Flange	
	Port	Female ¼-28 UNF/ M6 flat bottom ports	
Connection center-to-center distance		0.44	in
Connection edge-to-edge distance	Manifold ¼-28 UNF M6	0.4	in
		0.17	
		0.2	
Recommended mating connection	Manifold	Fluid channels	
	Port	Male ¼-28 UNF/ M6 nuts, preferably softer ETFE ferrules	
Recommended mating connection torque		≤0.35	lb in
Port connecting channel inner diameter		0.04	in
Internal volume	Manifold	40	µL
	Port	51	
Proof pressure		400	PSI
Burst pressure		800	PSI
Volumetric pressure expansion		50	nL/PSI
Loss coefficient (laminar local loss)		12.5	

## Product

Part Number	Variant
I²C PS200M 1 PACK	Manifold mountable version
I²C PS200F 1 PACK	¼-28 UNF port version
I²C PS200M6 1 PACK (custom product only)	M6 port version

## Sensing

Parameter	Value	Unit
Measurement type	Absolute	
Absolute range	3.63 to 203	PSI
Theoretical resolution	16	bit
Effective resolution	14.5	bit
Calibration	Factory	
Temperature compensation	Yes	
Full scale total error	±1	% FS
Absolute total error	±2	PSI
Noise level	≤10	mbar
Drift	±0.1	FS%/year
Absolute drift	±0.2	PSI/year
Data acquisition rate	67	ms

## Electrical

Parameter	Value	Unit
Minimum supply voltage	3.3	V DC
Maximum supply voltage	5.5	V DC
Recommended supply voltage	5.0	V DC
Supply power	40	mW
Output Signal	Digital	
Communication bus	I2C	
Bus configuration	Secondary	
I2C address type	7	bit
Default I²C address	0x5A (hex)	
	90 (decimal)	
Connection	Molex PicoBlade 53047-0510	
Recommended mating connection	Molex PicoBlade 51021-0500	

## Mechanical

Parameter	Variant	Value	Unit
Outer dimensions	Manifold Port	1.5 x 1.0 x 1.2 1.5 x 1.0 x 1.4	in
Mounting	Manifold Port	Flange Mounting screw hole	
Mounting orientation		Avoid having fluid ports above electrical connection	
Mounting hole inner diameter		0.13	in
Mounting hole length	Manifold Port	0.12 0.75	in
Recommended mounting screw		4-40 UNC, M3	
Housing material		PEEK	
Diaphragm material		Stainless steel 316L	
Seal material		FKM (Viton)	in

## Wiring

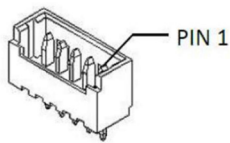

PIN	PIN NAME	DESCRIPTION
1	SDA	I2C DATA
2	SCL	I2C CLOCK
3	VDD	POWER INPUT
4	VSS	GROUND
5	PROG	DO NOT CONNECT
CHASSIS	VSS	CHASSIS IS CONNECTED TO VSS. AVOID POTENTIAL DIFFERENCES BETWEEN VSS AND CHASSIS GND

## Manifold Connection

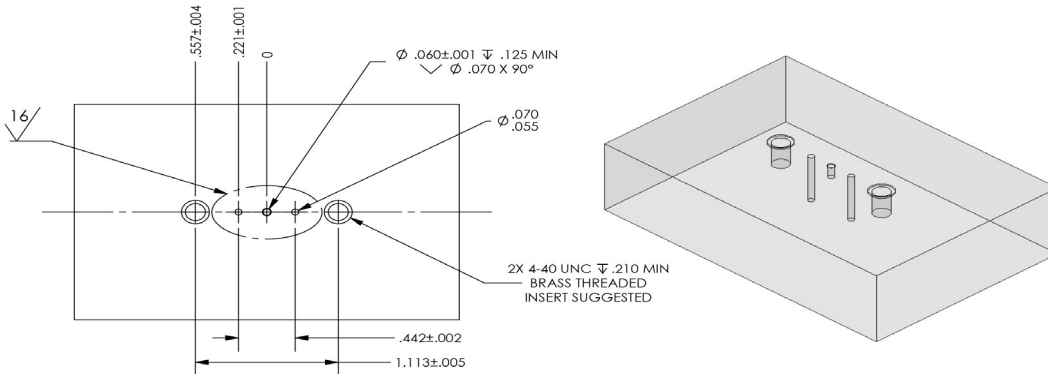

## Warranty

Seller warrants to buyer that each product will be free of defects in workmanship and material for the period of 1 year. The warranty period for all products commences on the date the product is deposited by the seller with the carrier for shipment. For complete warranty details refer to IDEX Health & Science LLC terms and conditions of sale which can be found at <https://www.idex-hs.com/about-us/legal-notices/terms-conditions-of-sale>.

## Environmental

Parameter	Value	Unit
Operation temperature	5 to 50	°C
Operation humidity, non-condensing	10 to 70	%
Storage temperature	-30 to 100	°C
Storage humidity, non-condensing	10 to 70	%

## Regulatory

Parameter	Value
Compliance	RoHS, REACH
Country of origin	Assembled in USA

## Dimensions

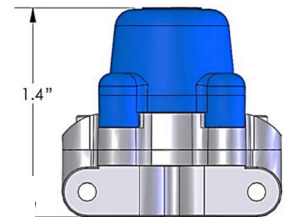
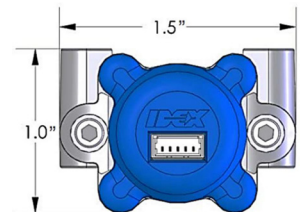

**Global Premium Distributor:**  
 Biotech Fluidics AB - Europe | Biotech LLC - USA  
 | Bionik Inc - Japan | [www.biotechfluidics.com](http://www.biotechfluidics.com)  
[info@biotechfluidics.com](mailto:info@biotechfluidics.com) | +46 300 56 91 80