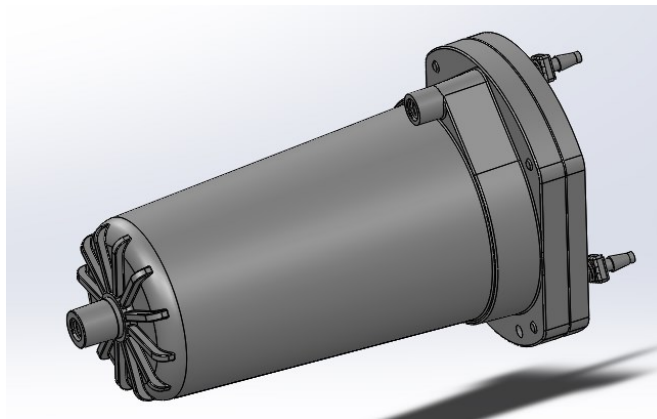

9000-1985

DEGASi Prep+ Chamber for Preparative Degassing**Description**

9000-1985 is a degassing chamber for high flow rate (>20ml/min) application. It achieves 50% degassing efficiency (water) at 100ml/min.

**CHAMBER TECHNICAL DATA (9000-1985)**

Degassing Chamber Tubing:	Systec AF [®]
Degassing chamber Volume:	23 ml / channel
Degassing Channel Pressure Rating:	50 PSIG
Wetted Materials:	Systec AF, FEP, Tefzel, PTFE, and Glass-filled PPS (Polyphenylene Sulfide)
Liquid Connections:	¼ - 28 UNF
Degasser Nominal Gradient Performance:	100mL/ min
Maximum Flow Rate:	200ml/min

Chemical Compatibility

Compatible with all common organic solvents normally used in preparative chromatography.

Regulatory Compliance Information

As of the date of publication, this product is compliant with current RoHS and regulations.

Country of Origin

Assembled in USA

Degassing Performance

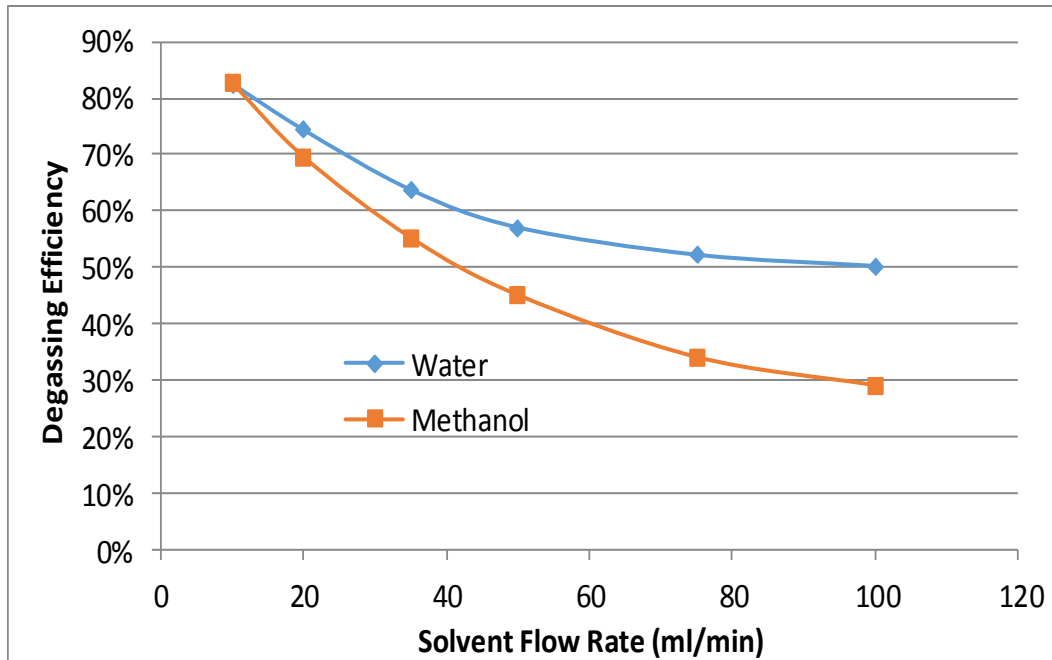

Dimensional Drawing

Dimensions are in inches and millimeters [mm]

